

SHINGLE

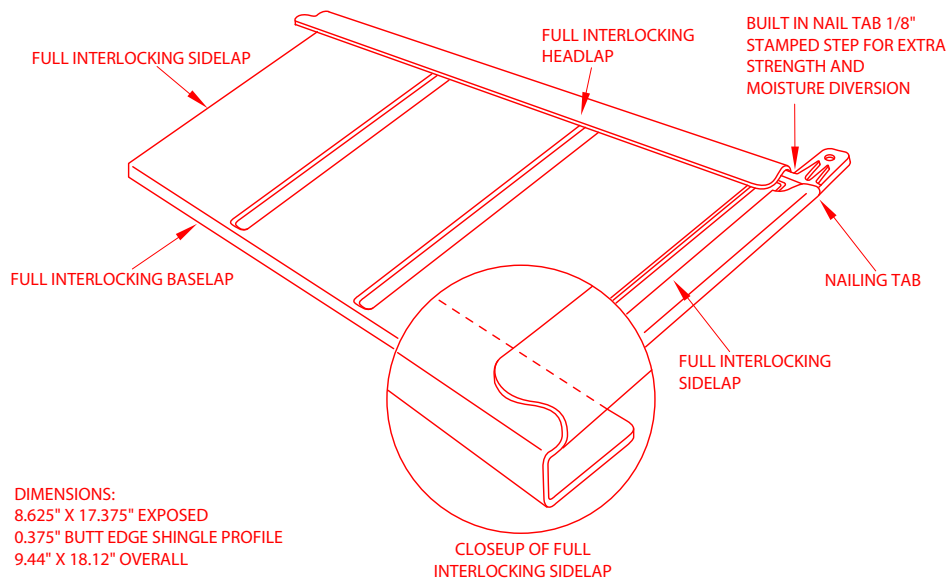

FUTURE ROOF® SYSTEMS
9969 RIVER WAY
DELTA, B.C. CANADA V4G 1M8

DATE: JUNE 2003
FILE: AS_SHINGLE_A

SECTION: 1
PAGE

STARTER & RAKE
(10 FT.)

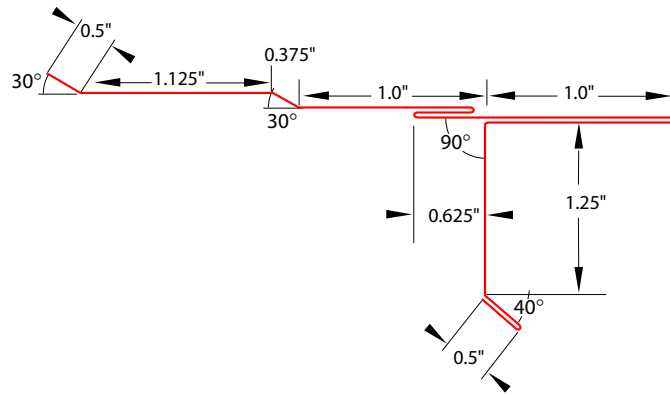

FUTURE ROOF[®] SYSTEMS
9969 RIVER WAY
DELTA, B.C. CANADA V4G 1M8

DATE: JUNE 2003
FILE: AS_START_A

SECTION: 1
PAGE

STARTER DETAIL

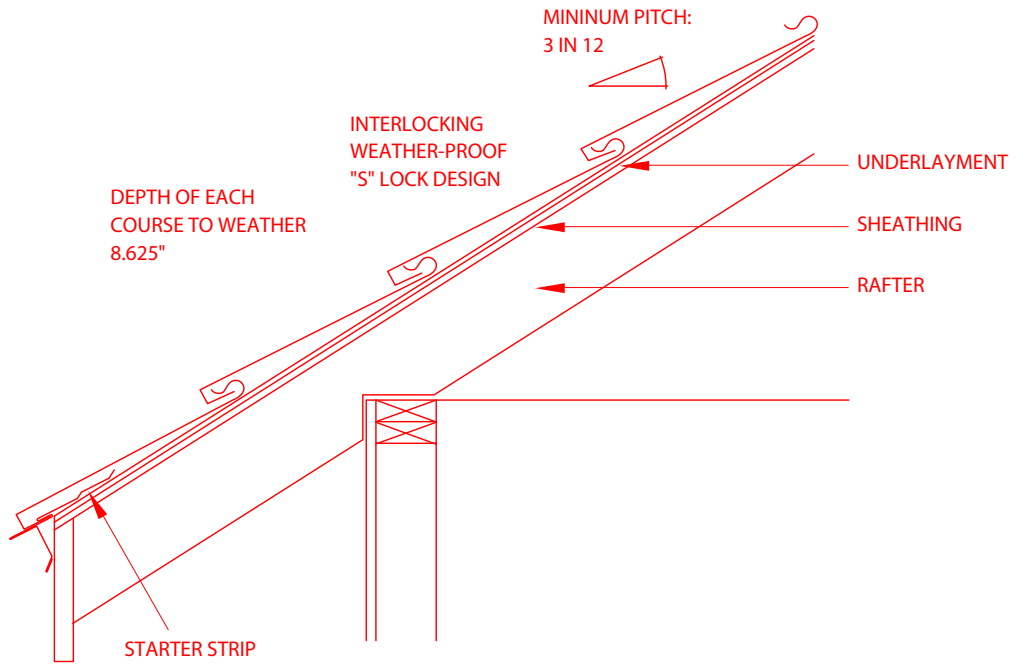

FUTURE ROOF® SYSTEMS
9969 RIVER WAY
DELTA, B.C. CANADA V4G 1M8

DATE: JUNE 2003
FILE: AS_START_D

SECTION: 1
PAGE

VALLEY
(10 FT.)

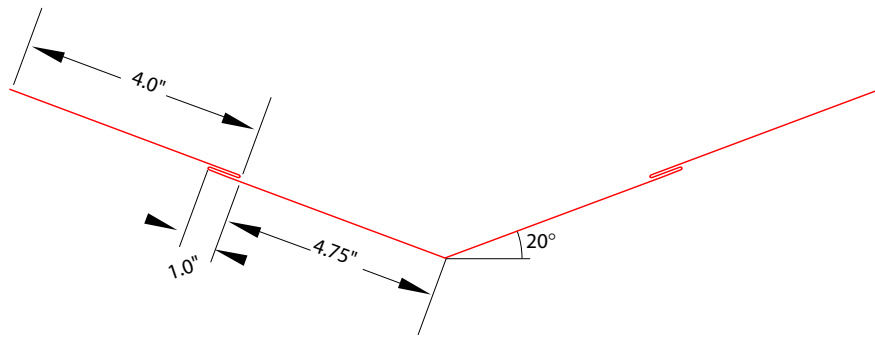

FUTURE ROOF[®] SYSTEMS
9969 RIVER WAY
DELTA, B.C. CANADA V4G 1M8

DATE: JUNE 2003
FILE: AS_VAL_A

SECTION: 1
PAGE

VALLEY DETAIL

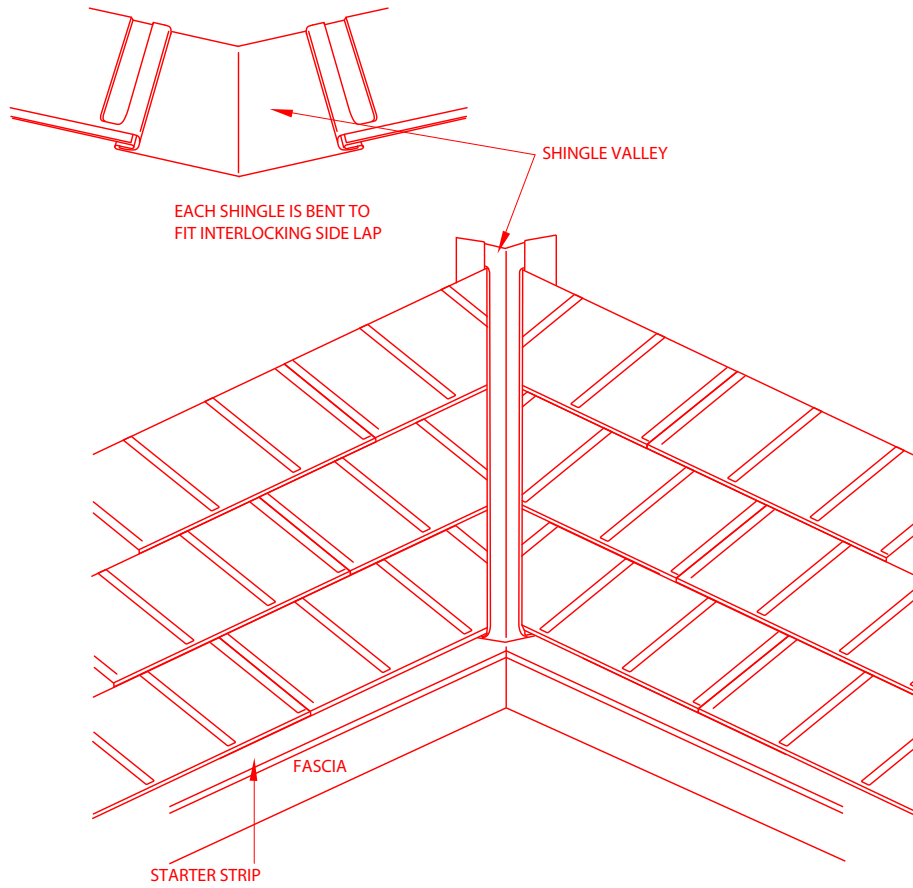

FUTURE ROOF® SYSTEMS
9969 RIVER WAY
DELTA, B.C. CANADA V4G 1M8

DATE: JUNE 2003
FILE: AS_VAL_D

SECTION: 1
PAGE

GABLE END OR RAKE DETAIL

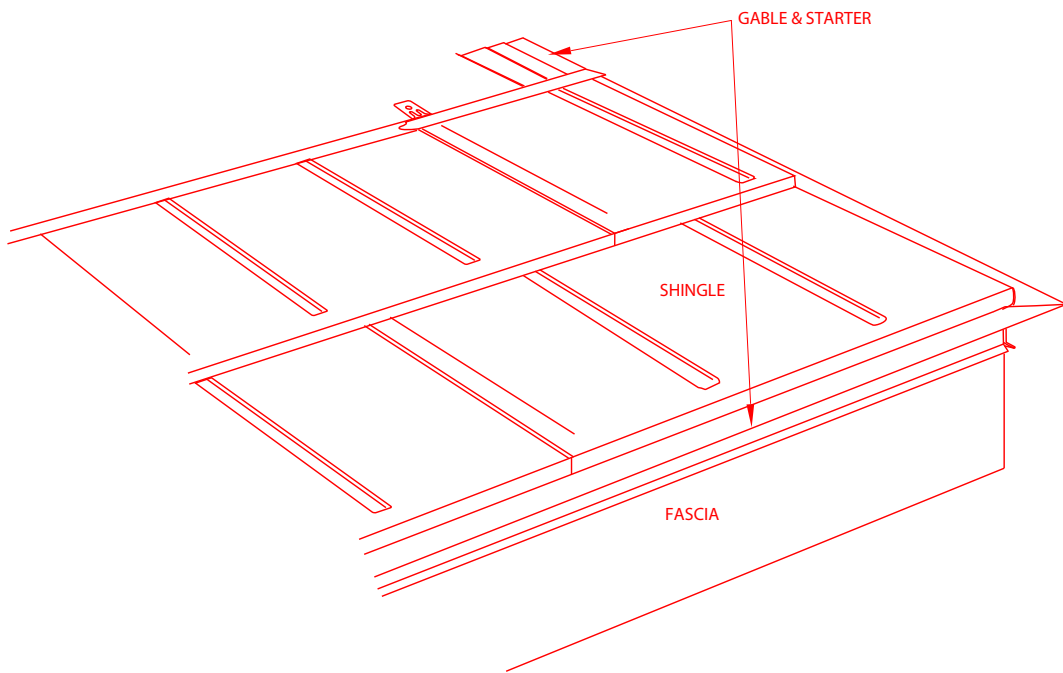

FUTURE ROOF® SYSTEMS
9969 RIVER WAY
DELTA, B.C. CANADA V4G 1M8

DATE: JUNE 2003
FILE: AS_GARA_D

SECTION: 1
PAGE

HIGH PROFILE
HIP & RIDGE SHINGLE TRIM

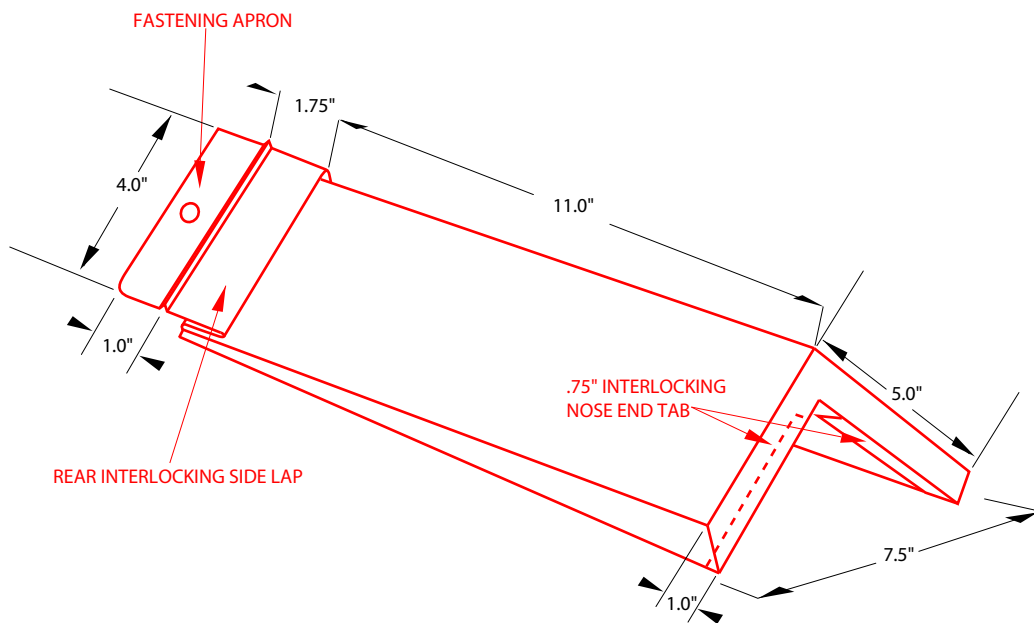

FUTURE ROOF[®] SYSTEMS
9969 RIVER WAY
DELTA, B.C. CANADA V4G 1M8

DATE: JUNE 2003
FILE: AS_HIPRISHINTRIM_A

SECTION: 1
PAGE

HIP DETAIL

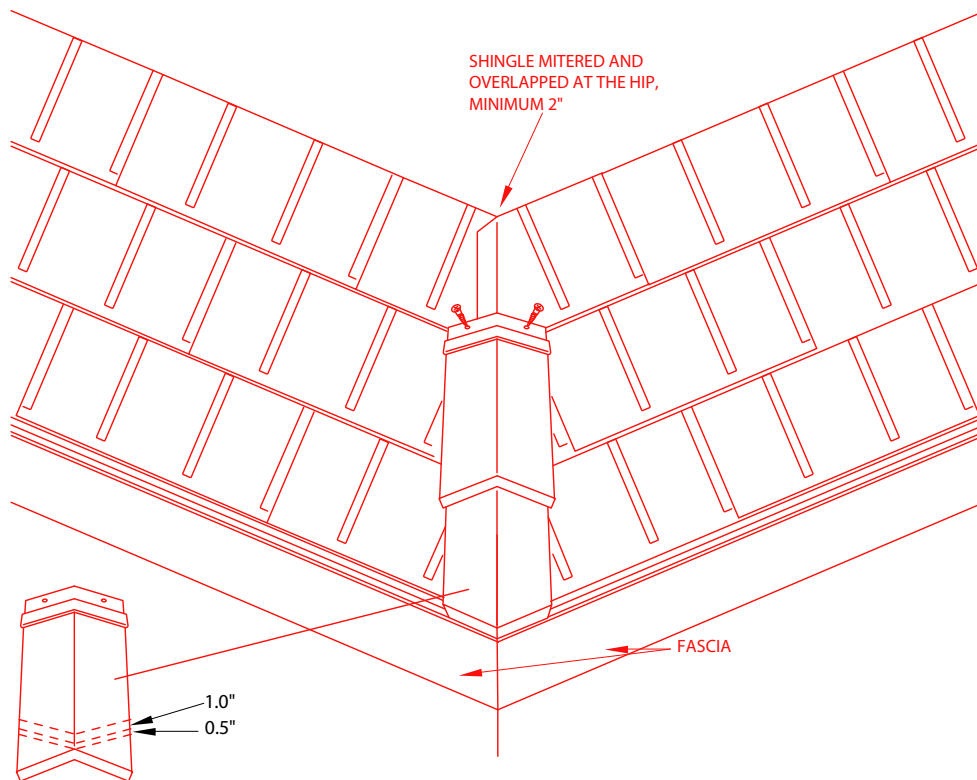

Hip Starter is made by cutting the top of the shingle hip and ridge back approximately 1.5". With the bending tool form the interlocking nose end tabs at 90° approximately 1.0" above bend again at 90° to complete the hip starter. The interlocking nose end tabs fit under the starter strip nose end . Pull back and fasten.



FUTURE ROOF® SYSTEMS
9969 RIVER WAY
DELTA, B.C. CANADA V4G 1M8

DATE: JUNE 2003
FILE: AS_HIP_D

SECTION: 1
PAGE

OVAL, GAMBREL & RIDGE

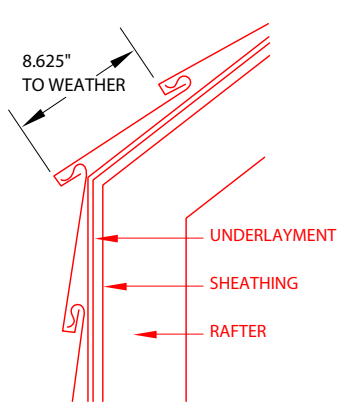
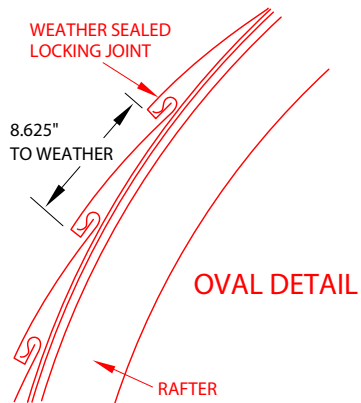

GAMBREL DETAIL

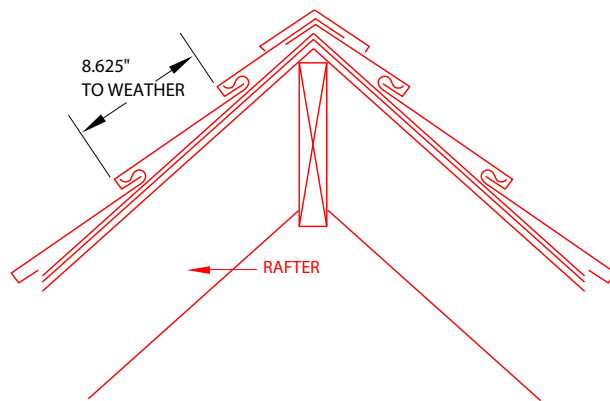

RIDGE DETAIL



FUTURE ROOF® SYSTEMS
9969 RIVER WAY
DELTA, B.C. CANADA V4G 1M8

DATE: JUNE 2003
FILE: AS_OVGAMRI_D

SECTION: 1
PAGE

COLLAR
(10 FT.)

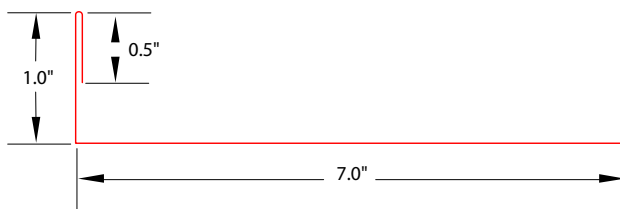

FUTURE ROOF® SYSTEMS
9969 RIVER WAY
DELTA, B.C. CANADA V4G 1M8

DATE: JUNE 2003
FILE: AS_COL_A

SECTION: 1
PAGE

ENDWALL & SIDEWALL
(10 FT.)

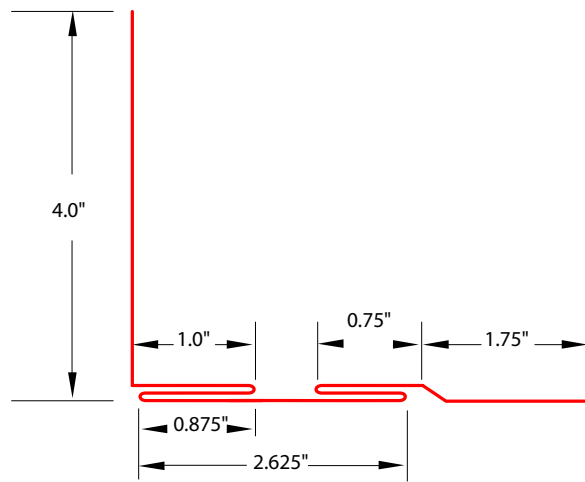

FUTURE ROOF[®] SYSTEMS
9969 RIVER WAY
DELTA, B.C. CANADA V4G 1M8

DATE: JUNE 2003
FILE: AS_ENDWLSIDWL_A

SECTION: 1
PAGE

PIPE FLASHING

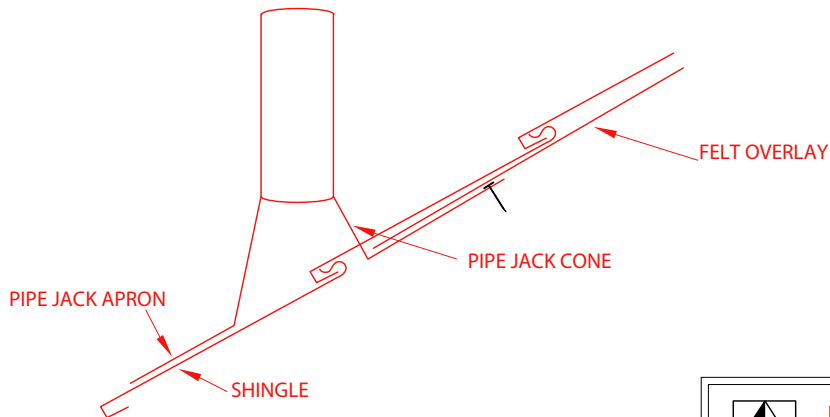
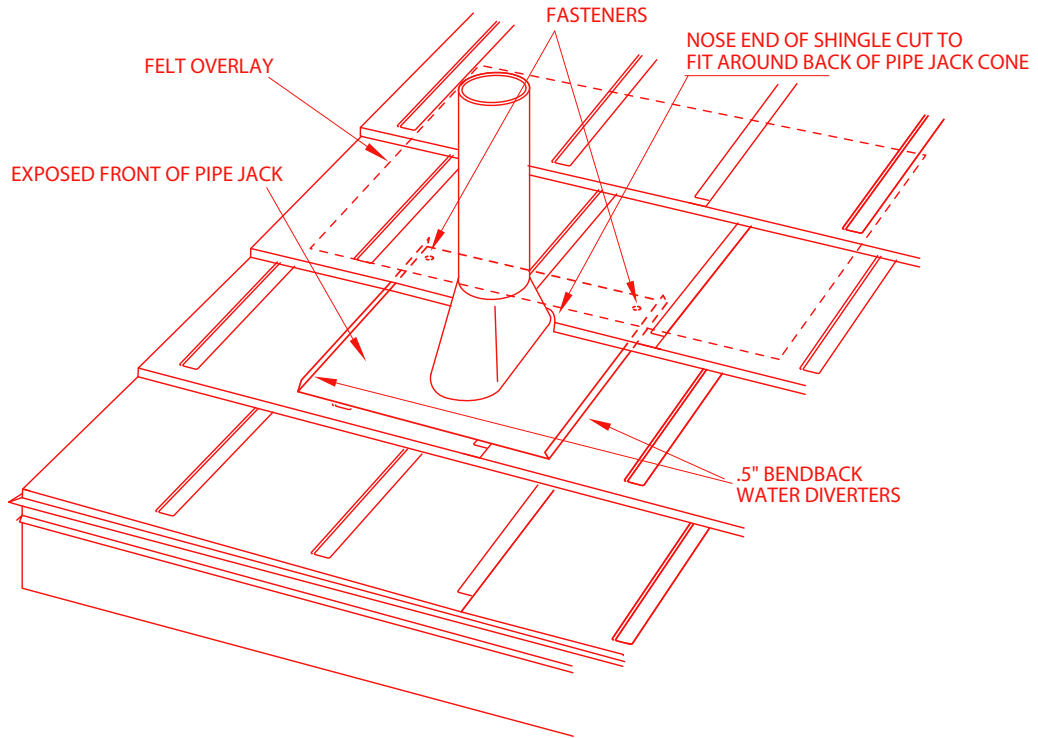

FUTURE ROOF® SYSTEMS
9969 RIVER WAY
DELTA, B.C. CANADA V4G 1M8

DATE: JUNE 2003
FILE: AS_PIPFL_D

SECTION: 1
PAGE

END & SIDE WALL DETAIL

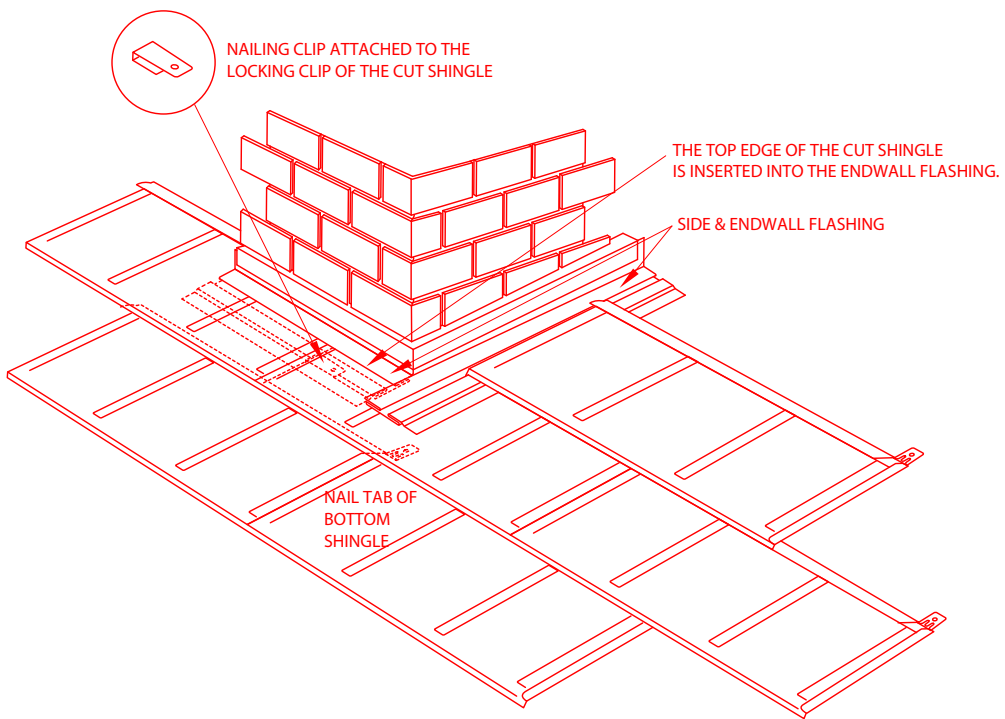

FUTURE ROOF[®] SYSTEMS
9969 RIVER WAY
DELTA, B.C. CANADA V4G 1M8

DATE: JUNE 2003
FILE: AS_ENDSIDWAL_D

SECTION: 1
PAGE